

Chapter 2

PON Architectures

Passive Optical Network (PON) [112] is a set of technologies standardized by ITU-T and IEEE, although it is originally created by the Full Service Access Network (FSAN) working group. PON is a converged infrastructure that can carry multiple services such as plain old telephony service (POTS), voice over IP (VoIP), data, video, and/or telemetry, in that all of these services are converted and encapsulated in a single packet type for transmission over the PON fiber. PON consists of three main parts [63].

- **Optical Line Terminal (OLT):** The OLT is located at the service provider's central office. It provides the interface between PON and the backbone network.
- **Optical Network Unit (ONU):** The ONU is located near end users. It provides the service interface to end users.
- **Optical Distribution Network (ODN):** The ODN in PON connects the OLT at the central office and ONUs near user homes by using optical fibers and splitters. The ODN usually forms a tree structure with the OLT as the root of the tree and ONUs as leaves of the tree.

There are three main types of PONs depending on the data multiplexing scheme. The currently deployed PON technology is time division multiplexing (TDM) PON, where traffic from/to multiple ONUs are TDM multiplexed onto the upstream/downstream wavelength. Wavelength division multiplexing (WDM) PON and orthogonal frequency division multiplexing (OFDM) PON constitute another two types of PON technologies [78, 111]. WDM PON uses multiple wavelengths to provision bandwidth to ONUs, while OFDM PON employs a number of orthogonal subcarriers to transmit traffic from/to ONUs. With the WDM or OFDM technology, these PONs are potentially able to provide higher than 40 Gb/s data rate and even Tera bps data rate.

Figure 2.1 shows the evolution of PONs. TDM is the multiplexing scheme for all PONs which have been standardized until now. Numerous research articles in tackling challenges in WDM PON have been published since WDM PON was first proposed in 1986 [86]. However, it has not been included in the standard yet mainly

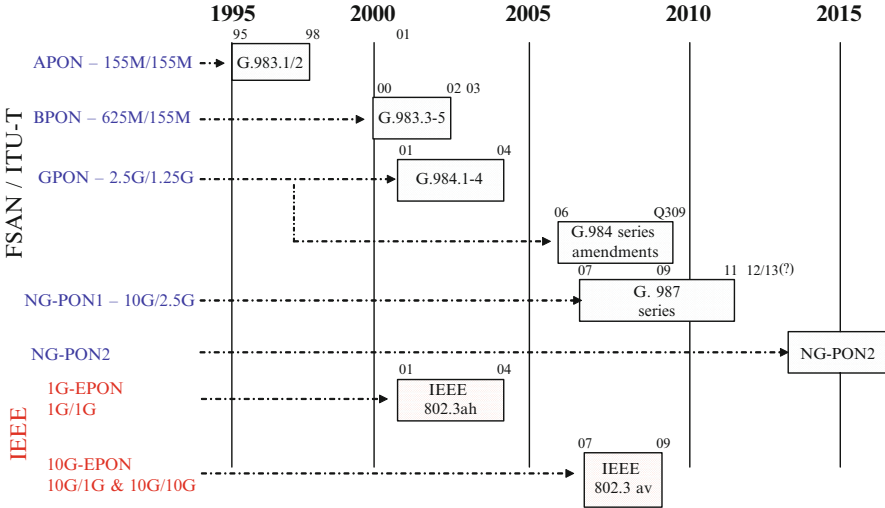

Fig. 2.1 Evolution of PON

due to the high system cost. OFDM PON has received intensive research attention in recent years owing to its high bandwidth provisioning. Both WDM PON and OFDM PON are considered as future PON technologies.

2.1 TDM PON

The currently deployed PON systems are TDM PON systems, which include ATM PON (APON), Broadband PON (BPON), Ethernet PON (EPON), Gigabit PON (GPON), 10G EPON, and Next-generation PON (NG-PON) to provision different data rates [18, 27, 55].

APON/BPON, GPON, and NG-PON architectures were standardized by the Full Service Access Network (FSAN), which is an affiliation of network operators and telecom vendors. Since most telecommunications operators have heavily invested in providing legacy TDM services, these PON architectures are optimized for TDM traffic and rely on framing structures with a very strict timing and synchronization requirements.

EPON and 10G-EPON are standardized by the IEEE 802 study group. They focus on preserving the architectural model of Ethernet. No explicit framing structure exists in EPON, and Ethernet frames are transmitted in bursts with a standard inter-frame spacing.

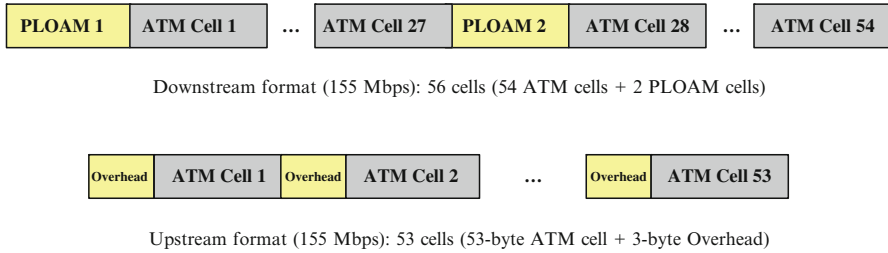

Fig. 2.2 APON frame format

2.1.1 APON/BPON (ITU-T G.983)

APON, ATM PON, is the initial PON specifications defined by the FSAN committee. APON uses ATM as their signaling protocol in layer 2. In APON, downstream transmission is a continuous ATM stream at a bit rate of 155.52 Mb/s or 622.08 Mb/s. Upstream transmission is in the form of bursts of ATM cells.

Figure 2.2 shows APON frame formats. The upstream channel is divided into 53 slots of 56 bytes at 155.520 Mbps, while the downstream cell stream is divided into frames of 56 cells at 155.520 Mbps. Physical Layer Operation, Administration and Maintenance (PLOAM) cells are inserted at the beginning and in the middle of a downstream frame. Each PLOAM cell contains 27 grant fields and a 12-byte message field. Grant fields are used to control the upstream data transmission, and message fields are used to control the operation of the ONUs.

In the upstream frame, a 3-byte overhead header is transmitted before a 53-byte ATM cell in each slot. The 3-byte overhead contains a minimum of four bits of guard time, a preamble, and a delimiter field. The guard time is to ensure a sufficient distance between two continuous cells to prevent collisions. The preamble field is used to extract the phase of the incoming ATM cell and acquire bit synchronization. The delimiter field is a unique bit pattern indicating the start of an incoming cell. PLOAM cells may be transmitted instead of ATM cells in the upstream frame to convey the physical layer information of an ONU to the OLT.

Broadband PON (BPON), as defined in ITU-T G.983 series, is a further improvement of the APON system. With the objective of achieving early and cost-effective deployment of broadband optical access systems, BPON offers numerous broadband services including ATM, Ethernet access, and video distribution. BPON employs wavelength division multiplexing (WDM) for downstream transmission, with as many as 16 wavelengths with 200 GHz spacing or 32 wavelengths with 100 GHz spacing between channels. BPON also provides enhanced security through the churning technique in which the encryption key is changed at least once a second between the Optical Line Terminal (OLT) at the headend and the Optical Network Terminal (ONT) at the customer premises.

2.1.2 GPON (ITU-T G.984)

ITU-T G.984 series, completed by FSAN, specifies various aspects of GPON, including the general architecture, the physical layer, the transmission convergence (TC) layer, and the GPON management and control [46]. GPON supports various bit rate options using the same protocol, including a symmetrical data rate of 622 Mb/s in both downstream and upstream, a symmetrical data rate of 1.244 Gb/s in both streams, as well as a data rate of 2.488 Gb/s in downstream and a data rate of 1.244 Gb/s in upstream. 2.488 Gb/s of downstream bandwidth and 1.244 Gb/s of upstream bandwidth are the data rates supported by typical GPON systems.

GPON defines the GPON encapsulation method (GEM) to achieve efficient packaging of user traffic, with frame segmentation to better provide quality of service (QoS) for delay-sensitive traffic such as voice and video applications. It accommodates three layer-2 networks: ATM for voice, Ethernet for data, and proprietary encapsulation for video, thus enabling GPON with full-service support capability, including voice, time division multiplexing (TDM), Ethernet, ATM, leased lines, and wireless extension. GPON also supports radio frequency (RF) video transmission in the waveband from 1,550 to 1,560 nm.

GPON directly reflects the requirements of network operators because the GPON standardization is driven by operators through FSAN. Similar to APON/BPON, GPON provides high product interoperability by standardizing a management interface, referred to as the optical network unit management and control interface (OMCI), between OLTs and ONUs/ONTs. It provides strong Operation Administration, Maintenance, and Provisioning (OAM&P) capabilities offering end-to-end service management.

2.1.3 NG-PON (ITU-T G.987)

Having completed the mission on GPON, ITU-T/FSAN has since been investigating next-generation PON (NG-PON) with higher bandwidth provisioning [135]. The evolution of NG-PON is divided into two phases: NG-PON1 and NG-PON2. NG-PON1 focuses on PON technologies that are compatible with GPON standards (ITU-T G.984 series) as well as the current optical distribution network (ODN). NG-PON1 is backwardly compatible with existing fiber installations, and tries to facilitate high bandwidth provision, large split ratio, and extended network reach. The objective of NG-PON2 is to provision an independent PON system, without being constrained by the GPON standards and the currently deployed outside plant.

As being standardized in ITU-T G.987, NG-PON1 specifies both asymmetric and symmetric 10G-PONs [50]. Figure 2.3 illustrates the NG-PON1 architecture. Asymmetric 10G-PON, also referred to as XG-PON1, provides the downstream data rate of 9.95328 Gbit/s and the upstream data rate of 2.48832 Gbit/s. This architecture upgrades the downstream link capacity to 10 Gb/s. The difficulty of the architecture in provisioning 10 Gb/s is to enable the burst mode time-division multiple access

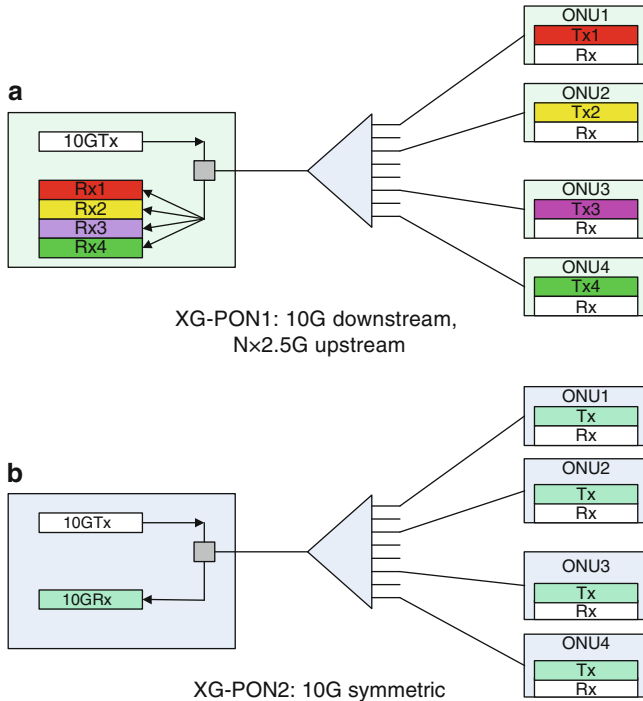

Fig. 2.3 XG-PON architecture

(TDMA) operated at 10 Gb/s. Owing to the limitation of available components and design practices, many simple circuit techniques become impractical when the rate goes beyond 5 Gb/s. Overcoming this limit requires specialized hardware and is thus costly.

To minimize the incurred additional investment, an architecture was proposed to upgrade only the downstream to 10 Gb/s, but to use one or more 2.5 Gb/s wavelengths in the upstream as shown in Fig. 2.3a. This architecture can still be considered as a TDM system both in the downstream and upstream. The downstream transmission can be modeled as 32 ONUs sharing a 10 Gb/s link. Depending on the number of available upstream wavelengths, the ONUs in the upstream scenario are divided into a different number of groups operating at 2.5 Gb/s. If two wavelengths are adopted in the upstream, the ONUs in the upstream scenario are divided into two virtual groups, each of which has 16 ONUs sharing a 2.5 Gb/s upstream link. If one wavelength is adopted, it can be abstracted as 32 ONUs sharing a 2.5 Gb/s upstream link from the MAC layer's perspective.

Symmetric 10G-PON, referred to as XG-PON2, achieves 10 Gbit/s in both upstream and downstream. However, XG-PON2 requires cost-inefficient burst-mode transmitters at ONU sides to deliver the upstream transmission speed. When devices capable of a 10 Gb/s burst mode become commercially available, the architecture with both the downstream and upstream transmission being upgraded to 10 Gb/s can be realized (see Fig. 2.3b).

2.1.4 EPON (IEEE 802.3ah)

EPON is developed based on Ethernet technologies, and enables seamless integration with IP and Ethernet technologies [58]. Owing to the advantages of fine scalability, simplicity, multicast convenience, and the capability of providing full-service access, EPON has been rapidly adopted in Japan and is also gaining momentum with carriers in China, Korea, and Taiwan since the IEEE ratified EPON as the IEEE 802.3ah standard in June 2004 [10].

EPON is a point to multipoint (P2MP) network topology implemented with passive optical splitters, along with optical fiber physical media dependent (PMD) sublayers that support this topology. EPON is based upon a mechanism referred to as MultiPoint Control Protocol (MPCP), which uses messages, state machines, and timers, to control access to a P2MP topology. Each ONU in the P2MP topology contains an instance of the MPCP protocol, which communicates with an instance of MPCP in the OLT. At the base of the EPON MPCP protocol lies the point to point (P2P) emulation sublayer, which makes an underlying P2MP network appear as a collection of point to point links to the higher protocol layers (at and above the MAC client). This is achieved by prepending a Logical Link Identification (LLID) at the beginning of each packet, replacing two octets of the preamble. In addition, a mechanism for network Operations, Administration and Maintenance (OAM) is included to facilitate network operation and troubleshooting.

The downstream traffic is continuously broadcasted to all ONUs, and each ONU selects the packets destined to it and discards packets addressed to other ONUs. In the upstream, each ONU transmits during the time slots that are allocated by the OLT. Upstream signals are combined by using a multiple access protocol, usually time division multiple access (TDMA). The OLT “ranges” the ONUs in order to provide time slot assignments for upstream communications. Owing to their burst transmission nature, burst-mode transceivers are required to fulfill the upstream transmission from an ONU to the OLT.

As compared to GPON, the burst sizes and physical layer overhead are large in EPON. As a result, ONUs do not need any protocol and circuitry to adjust the laser power. Also, the laser-on and laser-off times are capped at 512 ns, a significantly higher bound than that of GPON. The relaxed physical overhead values are just a few of many cost-cutting steps taken by EPON. Another key cost-cutting step of EPON is the preservation of the Ethernet framing format, which carries variable-length packets without fragmentation.

2.1.5 10G EPON (IEEE 802.3av)

Motivated to meeting the emerging high bandwidth demands, the IEEE 802.3av 10G-EPON task force was charged to increase the downstream bandwidth to 10 Gb/s, and to support two upstream data rates: 10 and 1 Gb/s [104, 131]. 10G-EPON supports both symmetric 10 Gb/s downstream and upstream, and asymmetric

10 Gb/s downstream and 1 Gb/s upstream data rates, while 1G-EPON provides only the 1 Gb/s symmetric data rate.

With the focus on the physical layer, the IEEE 802.3av Task Force specifies the reconciliation sublayer (RS), symmetric and asymmetric physical coding sublayers (PCSs), physical media attachments (PMAs), and physical media dependent (PMD) sublayers. Table 2.1 lists several key physical layer features of 10G-EPON [7]. Instead of using the 8B/10B line coding adopted in 1G-EPON, 10G-EPON employs 64B/66B line coding, with which the bit-to-baud overhead is reduced to as small as 3%. To relax the requirements for optical transceivers, Reed-Solomon code (255, 223) is chosen as the mandatory forward error correction (FEC) code in 10G-EPON to enhance the FEC gain, while Reed-Solomon code (255, 239) is specified as optional for 1G-EPON.

10G-EPON denotes PRX as the power budget for asymmetric-rate PHY of 10 Gb/s downstream and 1 Gb/s upstream, and PR as the power budget for symmetric-rate PHY of 10 Gb/s both upstream and downstream. Each power budget further contains three power budget classes: low power budget (PR(X)10), medium power budget (PR(X)20), and high power budget (PR(X)30). PR(X)10 and PR(X)20 power budget classes are defined in 1G-EPON as well, while PR(X)30, which can support 32-split with a distance of at least 20 km, is an additional one defined in 10G-EPON. For illustrative purposes, we only list the transmitter (Tx) type along with its launch power of 10G-EPON in Table 2.1. As compared to 1G-EPON, advanced transmitters and higher launch power are employed in 10G-EPON to guarantee a sufficient signal-to-noise ratio (SNR) at the receiver side for accurate recovery of data with a rate of 10 Gb/s. Because of the increased launch power, the power consumption of the optical transmitter should be increased accordingly. Also, owing to the mandatory FEC mechanism and increased line rate, the electronic circuit has to enable more functions and process faster than that in 1G-EPON, thus consequently incurring higher power consumption and possibly larger heat dissipation. Therefore, to accommodate 10 Gb/s in the physical layer, the power consumption of the OLT and the ONU may increase significantly.

For the MAC layer and layers above, in order to achieve backward compatibility such that network operators are encouraged to upgrade their services, 10G-EPON keeps the EPON frame format, MAC layer, MAC control layer, and all the layers above almost unchanged from 1G-EPON. This further implies that similar network management system (NMS), PON-layer operations, administrations, and maintenance (OAM) system, and dynamic bandwidth allocation (DBA) used in 1G-EPON can be applied to 10G-EPON as well.

Table 2.1 lists the specifications on data rates of several PON standards.

2.2 WDM PON

WDM PON is a candidate solution for next-generation PON systems in competition with 10G-EPON and NG-PON1 systems [60, 65]. To achieve high bandwidth provisioning, WDM PON supplies each subscriber with a wavelength rather than

Table 2.1 Data rate specifications of various PON standards

	APON/BPON	GPON	XG-PON1	EPON	10G-EPON
Standard	ITU-T G.983	ITU-T G.984	ITU-T G.987	IEEE 802.3av	IEEE 802.3av
Downstream speeds	622 Mbps	2.488 Gbps	9.9528 Gbps	1.25 Gbps	10.3125 Gbps
Upstream speeds	155 Mbps	1.244 Gbps	2.488 Gbps	1.25 Gbps	1.25 Gbps
			9.9528 Gbps		10.3125 Gbps

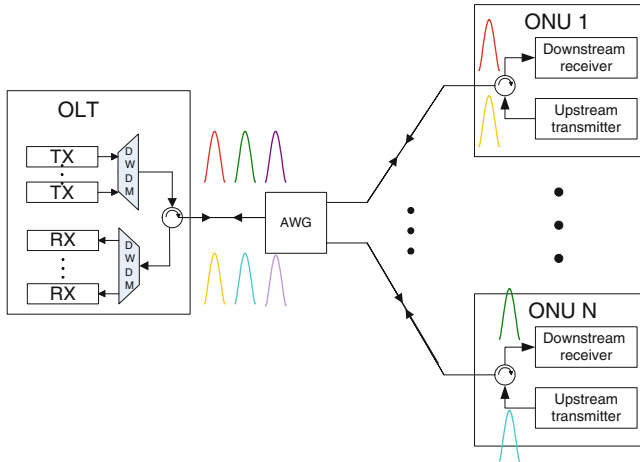

Fig. 2.4 A typical WDM PON architecture

sharing wavelength among 32 or even more subscribers in TDM PON. Figure 2.4 shows a typical WDM PON architecture. As early as 2006, WDM PON has already been deployed in Korea. However, owing to its high costs as compared to EPON and GPON, the deployment of WDM PON in other countries has been stalled.

WDM PON architecture enjoys several advantages over conventional TDM PON systems. First, WDM PON allows each user being dedicated with one or more wavelengths, thus allowing each subscriber to access the full bandwidth accommodated by the wavelengths. Second, WDM PON networks typically provide better security and scalability because each home only receives its own wavelength. Third, the MAC layer control in WDM PON is more simplified as compared to TDM PON because WDM PON provides P2P connections between the OLT and the ONU, and does not require the Point-to-Multipoint (P2MP) media access controllers found in other PON networks. Finally, each wavelength in a WDM PON network is effectively a P2P link, thus allowing each link to run at a different speed and with a different protocol for maximum flexibility and pay-as-you-grow upgrades.

Despite these attractive features, WDM PON is cost inhibitive because of the wavelength specific feature of ONUs. Since each subscriber is dedicated with some wavelengths, the OLT in WDM PON that supports 32 ONUs must transmit on no less than 32 different wavelengths, and each ONU should operate at their own wavelengths. The wavelength-specific feature of ONUs imposes higher requirements on lasers as compared to TDM PONs if the same kind of wavelength fixed lasers for all ONUs is employed. One solution is to use tunable lasers with which each ONU can be tuned to its desired wavelength. However, tunable lasers are costly. Another solution is to equip each subscriber with a wavelength-specific fixed tuned laser. Individual wavelength-specified sources cannot be readily employed in the OLT of WDM PON because they require a number of optical sources with different wavelengths. These cost-prohibitive devices constitute a major hurdle in early design of WDM PON systems.

The third solution is to let the OLT provide all optical sources to ONUs, and each ONU modulate the received unmodulated optical source. Two types of modulators, external modulator and semiconductor optical amplifier (SOA), can be used for this purpose. When the downstream optical signal is split at the ONU, part of it is provided to an external modulator or SOA for upstream data transmission. When the ONU is operated in this way, the power margin and the polarization (i.e., the direction of the electric field that varies randomly in normal optical fiber) of the optical signal must be considered because the shared source would experience a round-trip signal loss and the output of an external modulator usually varies with the input signal's polarization. At the same time, the cost of the modulator at each ONU may be an obstacle to its practical use. A reflective-type SOA, which can compensate for the round-trip signal loss, has been proposed for use as a shared source. The cost of the SOA still remains the major challenge for eventual commercialization.

2.3 OFDM PON

Orthogonal frequency division multiplexing (OFDM) PON[52, 90], as shown in Fig. 2.5, employs OFDM as the modulation scheme and exploits its superior transmission capability to improve the bandwidth provisioning of optical access networks. OFDM uses a large number of closely-spaced orthogonal subcarriers to carry data traffic. Each subcarrier is modulated by a conventional modulation scheme (such as quadrature amplitude modulation or phase-shift keying) at a low symbol rate, thus achieving the sum of the rates provided by all subcarriers compatible to those of conventional single-carrier modulation schemes in the same bandwidth. Since the data rate carried by each subcarrier is low, the duration of each symbol is relatively large. Thus, the inter-symbol interference can be efficiently reduced in a wireless multipath channel. In optical communications, the dispersion including chromatic dispersion and polarization mode dispersion has similar effects as those of multipath. Therefore, employing the OFDM modulation scheme in the optical access network can greatly increase the network provisioning data rate and lengthen the network reach.

OFDM has been successfully applied to ADSL, DVB-T, WLAN and WiMAX, and is a key transmission technology for next generation wireless systems including 3GPP LTE. In OFDM PON, cheaper electronic devices are used instead of costly optical devices, and ASIC-based DSP and AD/DA also reduce equipment costs. OFDM-PON can be combined with WDM to further increase the bandwidth provisioning, and has therefore become a competitive technology for NG-PON2. OFDM PON exhibits the following advantages:

- *Enhanced spectral efficiency*: Orthogonality among subcarriers in OFDM allows spectral overlap of individual subchannels. In addition, OFDM uses a simple constellation mapping algorithm for high-order modulation schemes such as

Fig. 2.5 OFDM PON architecture

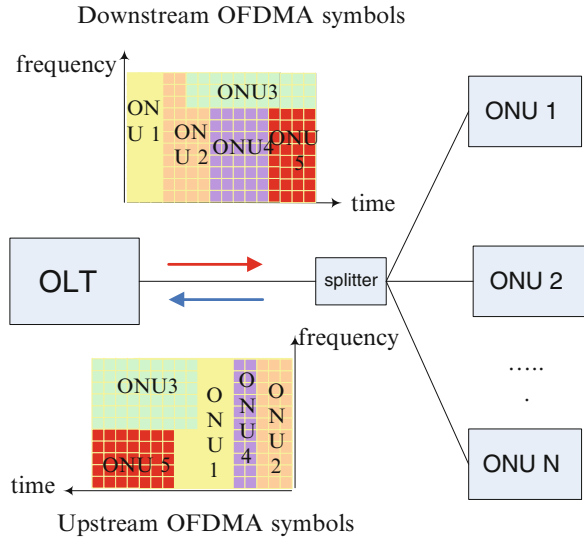

16QAM and 8PSK. Using these techniques, OFDM in PON makes effective use of spectral resources and improves spectral efficiency.

- *Avoiding costly optical devices and using cheaper electronic devices:* Integrated optical devices are very costly, and optical modules of 10G or higher can significantly drive up the cost of an access network. OFDM avoids costly optical devices and uses cheaper electronic devices. OFDM leverages on the integration and low-cost advantages of high-speed digital signal processors and high-frequency microwave devices to develop access networks.
- *Dynamic allocation of subcarriers:* Depending on channel environments and application scenarios, OFDM can dynamically allocate the number of bits carried by each subcarrier, determine the modulation scheme used by each subcarrier, and adjust the transmitting power of each subcarrier by using a simple FFT algorithm. In OFDM-PON, allocation of each subcarrier is executed in real time according to the access distance, subscriber type, and access service.
- *Converged wireline and wireless access:* An optical access network has enormous bandwidth potential and good QoS but lacks mobility, and is unable to meet the diverse requirements of different terminals. A wireless access network is more flexible and provides mobility, but suffers from poor QoS. OFDM is a mature technology in wireless communications that has been applied to WiMAX, WiFi and UWB (Ultra-wideband). By using OFDM to carry PON signals, wireline and wireless access can be converged. In other words, OFDM supports access to baseband OFDM, UWB (i.e., MultiBand-OFDM for UWB), WiMAX, WiFi, and millimeter-wave OFDM signals. Such versatility has significantly enhanced the universality of access networks.
- *Smooth evolution to ultra-long-haul access network:* A simple network structure improves the performance of an access network and reduces costs. Converged

optical core, metro, and access network has become a hot research topic, and long reach access networks have been proposed. Long-reach optical access suffers from the problem of high fiber chromatic dispersion. The OFDM modulation scheme can help address the chromatic and polarization-mode dispersion in optical links. Therefore, OFDM-PON can be used to smoothly evolve optical access networks to ultra-longhaul access networks.

In PONs, multiple ONUs share resources in the same feeder fiber connecting the OLT and ONUs. To ensure efficient transmission, a PON system must employ a proper MAC mechanism to arbitrate access to the shared medium in order to avoid data collisions and efficiently utilize the network resources.

2.4 Summary

This chapter discusses the evolution of passive optical networks and briefly describes the major PON technologies. There are three major PON technologies: TDM PON, WDM PON, and OFDM PON. The currently deployed PON networks are TDM PON systems. TDM PON has several flavors including ATM PON (APON), Broadband PON (BPON), Ethernet PON (EPON), Gigabit PON (GPON), 10G EPON, and XG-PON. WDM PON is a candidate solution for next-generation PON systems in competition with TDM PON systems. To achieve high bandwidth provisioning, WDM PON supplies each subscriber with a wavelength rather than sharing wavelengths among 32 or even more subscribers in TDM PON. Orthogonal frequency division multiplexing (OFDM) PON employs OFDM as the modulation scheme and exploits its superior transmission capability to improve the bandwidth provisioning of optical access networks.



<http://www.springer.com/978-1-4614-3938-7>

Media Access Control and Resource Allocation
For Next Generation Passive Optical Networks

Ansari, N.; Zhang, J.

2013, XVII, 111 p. 45 illus., Softcover

ISBN: 978-1-4614-3938-7